

# 4MX Series Transmitters

## Solid State AM Transmitters

### Where AM Technology Meets the Bottom Line



Model 4MX 50 shown

Based on our patented 4M Modulation design, the 4MX Series transmitters from Broadcast Electronics were designed with your bottom line in mind.

The 4MX Series packs unparalleled solutions, saving up to 33% in weight and 37% in required floor space. Its increased efficiency provides lower power consumption, reduced air conditioning costs, and lower installation and maintenance costs for a overall higher return on your AM investment.

The 4MX transmitters further strengthen your investment with superior quality and increased reliability, protecting your revenue stream from unexpected downtime.

Thinking about digital? The future-proofed 4MX provides you with the flexibility to convert to digital when you're ready. Designed for HD Radio™ and DRM, BE's 4MX transmitters accommodate both current and future versions of digital radio, ready for upgrade when you are!

When it comes to AM, no other transmitter provides more cost savings, flexibility and system design options than BE's 4MX. Designed to provide superior audio performance for your listeners, ensure maximum reliability and reduce on-going operating expenses, the 4MX Series ensures that you get the most out of your AM investment.

### Key Features & Benefits

- 88% typical efficiency reduces power and AC expenses
- One-third the footprint and weight of competing models
- Designed for analog AM, HD Radio and DRM
- Integrated spectrum/network analyzer eliminates additional costly equipment requirements
- Built-in redundancy keeps you on air even with a failed module
- Hot-pluggable power amplifier modules provide for easy, on-air maintenance
- 15" XGA graphical user interface for diagnostics and operation
- Standard IP-based remote control provides complete access from anywhere with a secured internet connection
- Power factor greater than 0.99
- Patented 4M Modulation design

Model	Description
4MX 25	250 W to 27.5 kW AM Transmitter
4MX 50	250 W to 55 kW AM Transmitter
4MX 100	250 W to 100 kW AM Transmitter



Tomorrow's Radio Today

# 4MX Series Transmitters

## Solid State AM Transmitters

### Complete Control at Your Fingertips

#### Main Menu

- Full transmitter control and diagnostic capabilities available locally via a 15-inch, 1024 x 768 XGA front-panel display, or remotely via IP from virtually anywhere on a secure network connection
- User interface provides intuitive soft-button operation for easy viewing of all pertinent transmitter status and advanced diagnostic information, as well as transmitter operational control
- Password and multi-layered access protection are provided
- Pertinent control and diagnostics available through standard discrete inputs and output

#### Network Sweep Menu

- Load Impedance Analysis provides impedance characteristics of the load
- Impedance and VSWR performance measurements with sideband frequencies from the carrier
- Displays load symmetry for analysis of AM HD operation

#### Spectrum Menu

- Provides spectrum output of the transmitter for analog and AM HD operation
- Allows spectrum settings for measurement of AM HD
- Verification of AM HD performance with AM HD filter mask

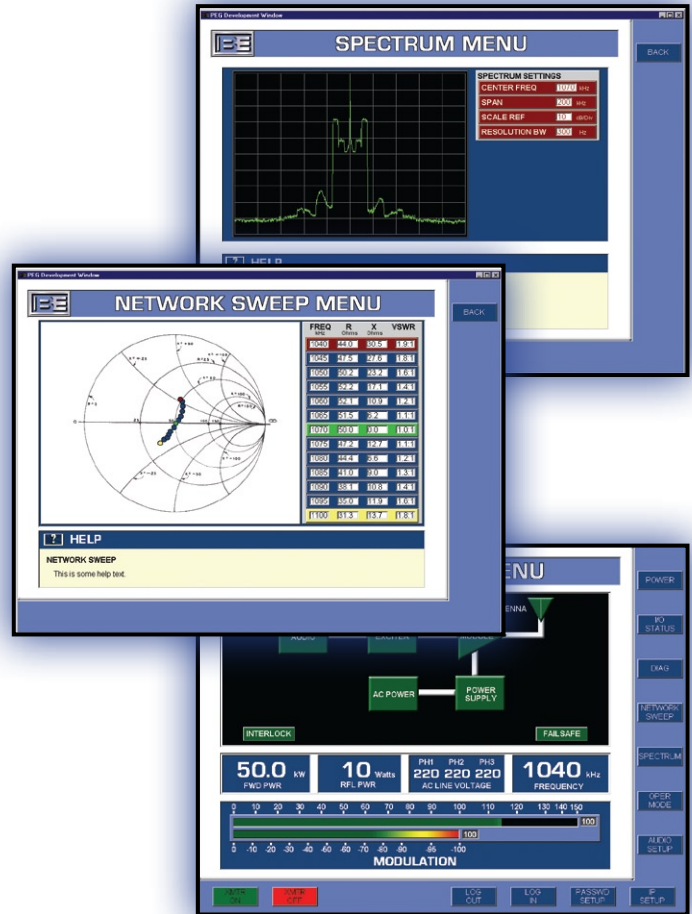

### How 4M Modulation Stacks Up

	Modulation Method	Efficiency	Power Range	Power Factor Correction	Power Consumption	Heat Dissipation	Air Conditioning Requirements	Size	Required Floor Space	Weight
BE Model	4M Modulation	88%	250 W-55 kW	.99	85.2 kW @ 75 kW	10.2 kW @ 55 kW	2.9 ton @ 55 kW	45" W x 35" D x 87" H	1575 sq in	1115 lbs
Competitive Models	Direct Digital Drive Amplitude Modulation	87%	10 kW-60 kW	.97	86 kW @ 50 kW	13.8 kW @ 50 kW	3.9 ton @ 50 kW	102" W x 42" D x 78" H	4284 sq in	3625 lbs
	PDM Modulation	84%	10 kW-60 kW	.95	89.3 kW @ 50 kW	14.3 kW @ 50 kW	4.06 ton @ 50 kW	53" W x 41" D x 72.5" H	2173 sq in	1950 lbs

All specs typical @ 100% tone modulation and 50 kW output power, unless otherwise noted.

# 4M Modulation Working for You

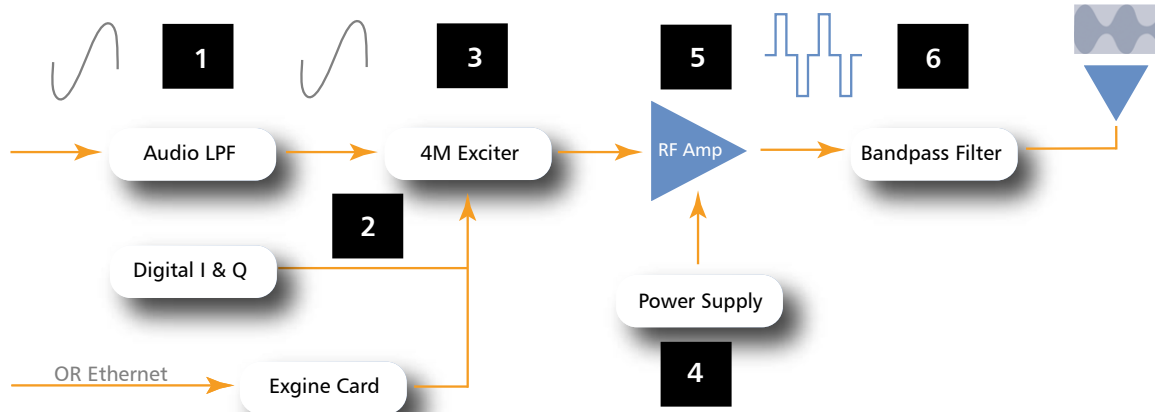

4MX Block Diagram

**1. Audio low pass filter for analog** The audio input filter for the analog signal limits the bandwidth for analog operation by protecting against unwanted high-frequency signals and noise.

**2. I and Q or Ethernet data input for HD Radio operation** The I and Q or Ethernet data input provides a path for the HD Radio signals to pass directly into the processor in front of the exciter. It is important to note that the usual path for entering the HD Radio amplitude signal is through the standard analog input. For PWM and digitally modulated transmitters, the analog filter has to be removed or modified in some way, which leaves the transmitter unprotected against undesirable audio or noise that may enter through this port during HD Radio operation.

**3. Exciter** The exciter provides the drive signal to each PA to create the amplified output waveform. The drive characteristics determine the duty cycle of the amplified waveform.

**4. Power supply** The power supplies are an important feature of the 4MX transmitter design. Running at 400 VDC, the power factor corrector supplies were designed to provide ultimate power efficiency and reliability for easy and efficient operations. The FET used in the power factor corrector circuit delivers 2.85 kW to meet the maximum requirement, although functional up to 6 kW output power. The power

factor correction inductor was designed for twice the actual current to keep losses at a minimum. The catch diode is the latest silicon-carbide diode, which improves the efficiency of the supply by half a percent. All these design implementations yield an efficient (97%) and reliable power supply. BE provides a one-to-one relationship between the power supplies and the power amplifiers. Each power supply operates only one PA with no bussing of power supplies. This scheme provides optimum redundancy for the system.

**5. Power amplifier** Each power amplifier has an H-Bridge topology; each runs independently of the other amplifiers in the transmitter and the output of each amplifier is in phase with all other modules. This is important because it allows the 4MX to operate on a single supply and power amplifier combination, resulting in excellent operation at very low powers. In addition, the same drive signal is applied to all PA modules. The drive to the power amplifier is key to the 4MX operation.

**6. Bandpass filter** The bandpass filter was designed to reduce the harmonics of the carrier to an acceptable level. The 4MX transmitter uses a bandpass filter designed to be broadband, with approximately 210 degrees of phase shift between devices and the output port. The bandpass filter also matches the ideal PA load impedance of 10 ohms to the 50 ohm output impedance.



# 4MX Series Transmitters

## Solid State AM Transmitters

### Improving AM Profitability

#### Increased efficiency leads to lower operating costs!

- With 88% efficiency typical, experience exceptional savings in annual power bills
- Less heat dissipated into the facility reduces cooling and ventilation costs
- Full on air redundancy and protection provides for low maintenance

#### On air maintenance protects your revenue stream!

- All power amplifiers operate independently, keeping you on air even with a failed module
- Repair/replacement of modules without taking your station off air
- Highly efficient, individual redundant power supplies control each amplifier
- Full RF module diagnostics provided without the need for additional access cards
- Minimum to no down time means you'll consistently maintain revenue generation

#### Anywhere, anytime access saves you time and money!

- Standard IP based remote control provides enhanced monitoring, control and diagnostics
- Full monitoring capabilities include spectrum and network monitoring, power amplifier status and complete control of the system operating parameters
- Password-protected access levels tailored to your station requirements

#### Operating at reduced power? One transmitter does it all!

- Innovative modulation design achieves unprecedented low power levels for all your power needs, day and night
- Eliminates cost of separate nighttime transmitter
- Unparalleled overall performance at full and reduced power
- Eliminates need to dump excess power or purchase costly power dividers
- Provides excellent audio quality even at reduced power levels

#### Plans to go digital? We're ready when you are!

- Digital ready as delivered from the factory
- Designed with digital in mind
- Accommodates both current and future versions of HD Radio
- Provides the flexibility of changing transmission between analog only mode and analog+HD mode on the fly either locally or remotely
- BE's ASi 10 HD Radio Signal Generator feeds I and Q directly to the transmitter
- A plug-in Engine module is all that is needed to configure HD Radio coding and processing in the studio using the XPi 10esp HD Radio Exporter/Encoder

Taking the next step is easy with Broadcast Electronics. Get in touch with your sales representative today to discuss solutions that will work for you and your station(s). To contact your BE sales representative, simply visit our website at [bdcast.com](http://bdcast.com) or call 217.224.9600 and learn more about what BE has to offer.

BE is the premier provider of mission-critical solutions for over-the-air and Internet radio. Our products encompass program generation, audio and data management, interfacility transport and analog and digital (HD Radio and DRM) transmission. They are used daily in more than 10,000 installations in nearly 100 countries.

For more than four decades, BE pioneering developments have set industry standards for innovation and reliability, while providing broadcasters with new options for operational productivity and income generation.

BE is headquartered in Quincy, IL, and is represented worldwide by a network of local representatives.

